

3) METHOD of ATTACHMENT to FORK ARMS

Before installation of the type FST 200 Slip-On Jib onto a forklift, ensure that the fork arms are NO LONGER than 1200mm and are suited and set to the correct width.

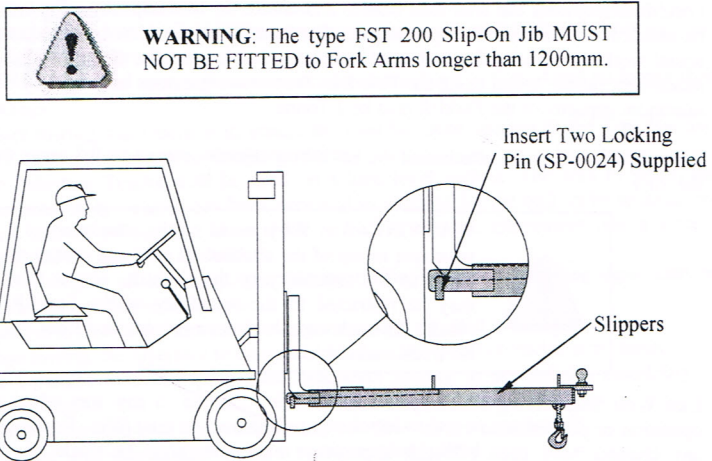

Fig. 3.1

To install the type FST 200 Slip-On Jib, engage the Forklift arms into the slippers as shown in *Fig. 3.1* above. With the Fork Arms positioned as far as possible into the slipper, Insert two locking pins supplied through the slipper.

4) OPERATIONAL and SAFETY PROCEDURES

Preliminary Safety Checks

A "Competent Person" shall inspect all components on the Jib to ensure they are in safe working order. Do not use the Jib if any of the components are damaged or not in safe working condition. A "Competent Person" shall inspect the Locking Pins, shackles, safety swivel hook assemblies and Tow Bar fittings daily to ensure that they are correctly fitted and in safe working order.

The Operator shall check that the Jib has been correctly fitted in accordance with these Instructions [refer Section (3)], and/or the relevant Industrial Truck Operator's Manual.

All signage must be strictly adhered to and ensure that the compliance plate is not damaged and is clearly legible.