



maximal
美科斯

USE AND MAINTENANCE MANUAL

M SERIES 1.8-3.5T
COMPACT ROUGH-TERRAIN FORKLIFT TRUCK



Hyster-Yale Maximal Forklift (Zhejiang) Co.,Ltd.

I. Forklift Truck Main Technical Parameters

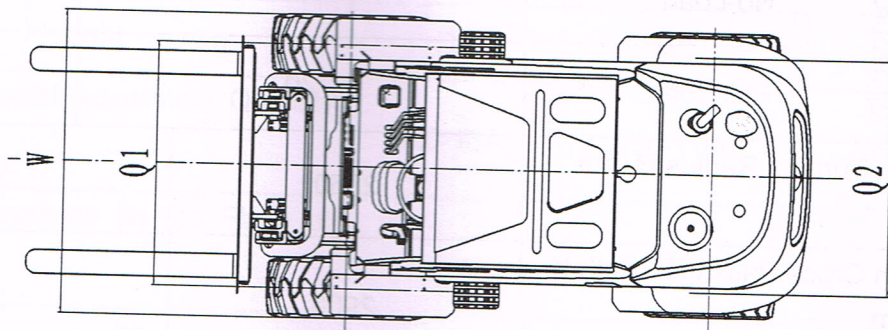
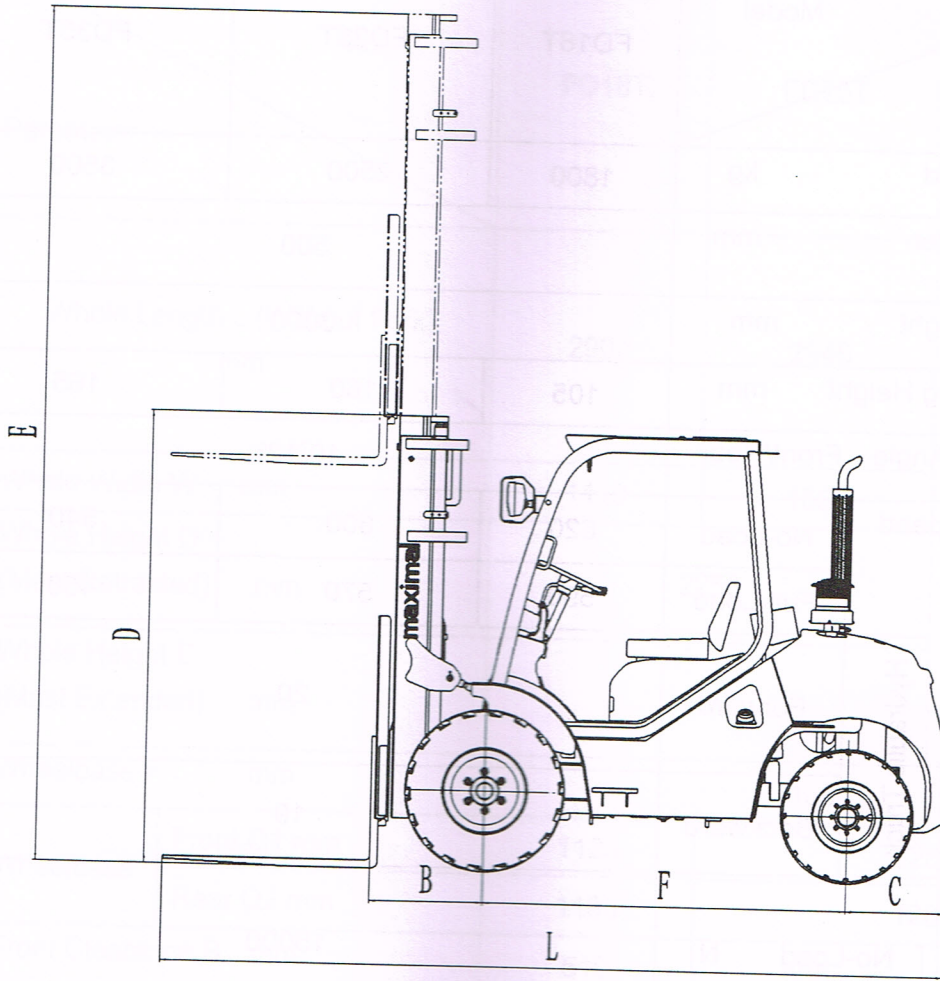

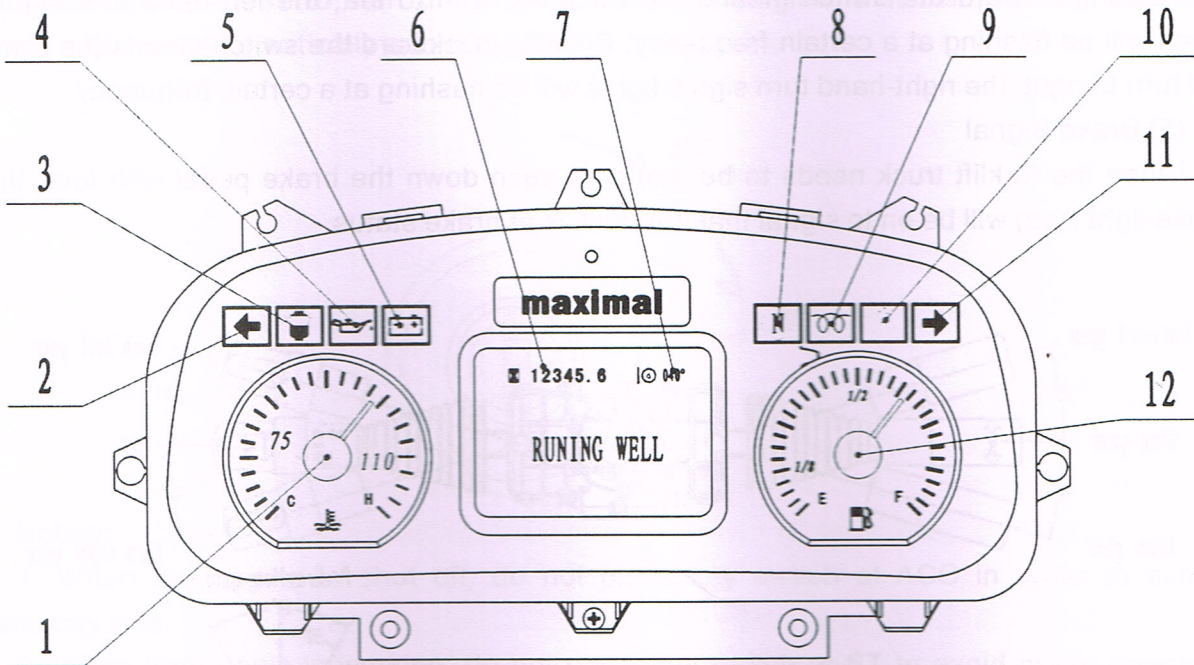

Table 1

Parameter		Model	FD18T	FD25T	FD35T
		Rated Load	kg	1800	2500
Load Center	mm	500			
Lifting Height	mm	3000			
Free Lifting Height	mm	105	160	165	
Mast Tilt Angle	Front/Rear	10/12°			
Lifting Speed mm/s	No-Load	620	600	540	
	Full-Load	590	570	450	
Running Speed km/h	Hydraulic Truck	Forward	20		
		Backward	19		
Max Traction Force	No-Load	N	15000		
	Full-Load	N	17000		
Gradeability	No-Load	%	20	20	
	Full-Load	%	20	16	
Min Turning Radius R mm			2850	2870	
Min Cross Passage Width K mm			2900	2920	

Table 2

Parameter		Model	FD18T	FD25T	FD35T
Size Parameter	Whole Length L (Without Fork) mm		2909	2946	2956
	Whole Width W mm		1440	1560	1600
	Whole Height D (Mast Retracted) mm		2256		2330
	Whole Height E (Mast Extended) mm		4175		4305
	Wheelbase F mm		1880		
	Wheelbase	Front Q1 mm	1125	1250	
		Rear Q2 mm	1185	1205	
	Front Clearance B mm		510	585	600
	Rear Clearance C mm		520		
	Fork Dimension	Length mm	1070	1070	1070
		Width mm	100	122	125
		Height mm	35	40	45
	Fork Horizontal Adjustment Quantity mm		200-1310	250-1160	250-1160
	Ground Clearance (in the Place of Mast) mm		270		
	Self Weight kg		3700	4465	5180



- 1: Water temperature gauge, indicates the water temperature of forklift truck engine;
- 2: Left turn indicator light, indicates the left turning work of the forklift;
- 3: Oil-water separation indicator indicates that the water content in the oil-water separator is too high, you need to manually drain;
- 4: Low oil pressure indicator light indicates low engine pressure;
- 5: Charge indicator light indicates the generator charging the battery;
- 6: Timer counts the working hours of the engine;
- 7: Torque converter oil temperature display shows the oil temperature of the gearbox torque converter;
- 8: Display gear state, neutral if N point flashes;
- 9: Preheating indicator, indicates the engine air preheating in progress;
- 10: Air filter clogging indicator, indicates the air filter clogged;
- 11: Right turn indicator light, indicates the right turning work of the forklift;
- 12: Show the amount of fuel oil remaining in the fuel tank.

9.5 Electric Box Introduction:

Electric Box is used mainly for relay and chip fuse installation. Chip fuse is used to protect the circuit. When short circuit occurs, it will prevent the electric devices and wires from being burnt. Relay expands the switch capacity. It enables switch with small capacity to control high power devices.

shall be periodically cleaned and removed, either to be soak cleaned using detergent, or to be flushed using compressed air or high-pressure water (pressure not larger than 4kg/cm).

6. Oils Used for Forklift Truck

Name	Brand or Code (Domestic)
Gasoline	93#
Diesel Oil	To be selected and used according to diesel engine operation and maintenance manual, or according to GB252-2015 Light Diesel Oil. Summer 0# Winter -10# -35#
Engine Oil	To be selected and used according to engine operation and maintenance manual, or according to Diesel Engine: GB11121-2006 standard requirements and the tough degree of its working conditions
Hydraulic Oil	L-HM32
Hydraulic Drive Oil	6# Hydraulic Drive Oil
Gear Oil	85W/90
Brake Fluid	ZSM207 DOT3 Synthetic Brake Fluid
Lubricating Oil	3# Lithium Base Lubricating Grease Drop Point 170

7. Drawing of Lubricating System

