

S2770/3370/3970RT

COMPACT ROUGH TERRAIN SCISSOR LIFTS



- Compact diesel rough terrain scissor lifts
- Excellent rough terrain performance
- Easy to operate
- Roll-out deck extension for extra reach
- Ideal for outdoor work in confined spaces

 **snorkel**
www.snorkellifts.com

COMPACT RT SCISSORS

S2770/3370/3970RT

DIMENSIONS	S2770RT	S3370RT	S3970RT
Max. working height	10.23m	12.1m	13.9m
Max. platform height (A)	8.23m	10.1m	11.9m
Platform size (stowed) (B)	2.71m x 1.65m	2.71m x 1.65m	2.71m x 1.65m
Platform size (extended) (C)	3.9m x 1.65m	3.9m x 1.65m	3.9m x 1.65m
Deck extension	1.2m	1.2m	1.2m
Overall width (D)	1.8m	1.8m	1.8m
Overall length (E)	3.4m	3.4m	3.4m
Stowed height (F)	2.59m	2.7m	2.95m
Min. height (guardrails folded)	1.83m	2.0m	2.13m
Ground clearance	330mm	330mm	330mm

PERFORMANCE

Platform capacity (SWL)	580kg	450kg	350kg
Max. drive height	8.23m	10.1m	11.9m
Max. wind speed	12.5m/s	12.5m/s	12.5m/s
Max. drive speed (stowed)	4.5km/h	4.5km/h	4.5km/h
Max. drive speed (elevated)	0.5km/h	0.3km/h	0.3km/h
Raise/lower time	26/30 sec	50/60 sec	50/60 sec
Gradeability	35%	35%	30%
Max. outrigger levelling, front to rear	6°	6°	7°
Max. outrigger levelling, side to side	10°	10°	11°
Inside turning radius	2.44m	2.44m	2.44m
Outside turning radius	4.75m	4.75m	4.75m
Tyres	27 x 10.5 - 15 foam filled lug		
Controls	proportional joystick		
Drive system	4 wheel drive	4 wheel drive	4 wheel drive

POWER

Power source Kubota D-902 water-cooled diesel 22.5hp

WEIGHT

Weight 2,800kg 3,620kg 3,790kg

TURNING RADIUS

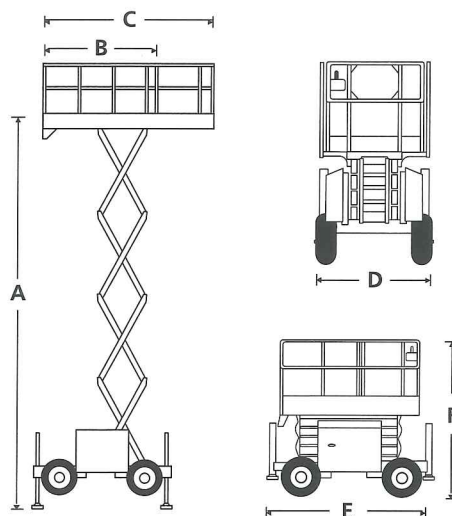
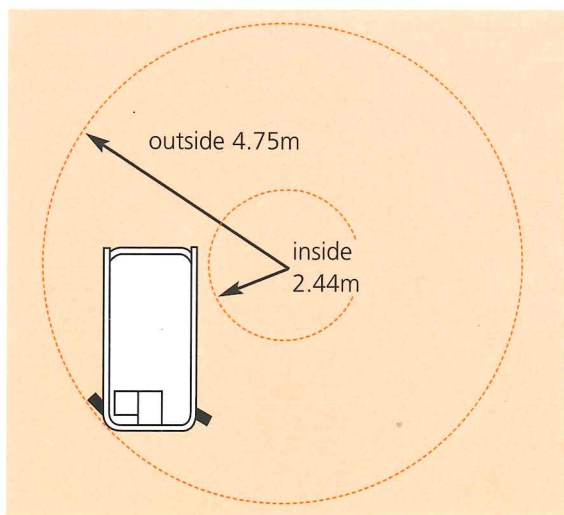

STANDARD FEATURES

- 4 wheel drive
- 4 hydraulic outriggers with automatic levelling
- Roll-out deck extension
- High grip, all-terrain tyres
- Proportional controls
- Power line to platform
- Drive motion alarm
- Descent alarm
- Manual lowering valve
- Flashing amber light
- Oscillating axle
- Horn
- Fold-down guardrails
- Hour meter & on-board diagnostics display
- Dual lanyard attachment points
- 2 year parts & labour, 5 year structural warranty
- CE approved

OPTIONS

- Special paint colours
- Non marking tyres
- LPG power
- Dual fuel
- Hydraulic generator 110V/240V
- Nylon spreader pads

snorkel

Nelson Crow
Sales & Marketing Manager
South Island, NZ

34 Birmingham Drive,
Christchurch 8024, P.O Box 7493