

Specifications

Model	Z-33/18	
Measurements	Metric	US
Working height maximum*	12 m	38 ft 10 in
Platform height maximum	10 m	32 ft 10 in
Horizontal reach maximum	5.57 m	18 ft 3 in
Up and over clearance maximum	4.28 m	14 ft 1 in
A Platform length	0.76 m	2 ft 6 in
A Platform width	1.17 m	3 ft 10 in
A Height - stowed	1.98 m	6 ft 6 in
A Length - stowed	4.17 m	13 ft 8 in
E Width	1.50 m	4 ft 11 in
F Wheelbase	1.90 m	6 ft 3 in
G Ground clearance - center	15.20 cm	6 in

Productivity

Lift capacity	200 kg	440 lbs
Turntable rotation	400° non-continuous	
Turntable tailswing	zero	
Drive speed - stowed	5.2 km/h	3.2 mph
Gradeability - stowed***	30%	
Turning radius - inside	1.90 m	6 ft 3 in
Controls	24V DC proportional	
Tyres	56x23x44 cm	22x9x17 in

Power

Power source	48 V DC (eight 6 V X 8 batteries 350 Ah capacity)	
Drive system	48 V 3 phase AC	
Auxiliary power unit	24 V DC	
Hydraulic tank capacity	20.8 L	6 gal

Sound & Vibration Levels

Sound pressure level (ground)	<70 dBA	
Sound pressure level (platform)	<70 dBA	
Vibration	<2.5 m/s ²	<8 ft 2 in/s ²

Weight****

	3,665 kg	8,079 lbs
--	----------	-----------

Standards Compliance

AS 1418.10

Range Of Motion Z-33/18

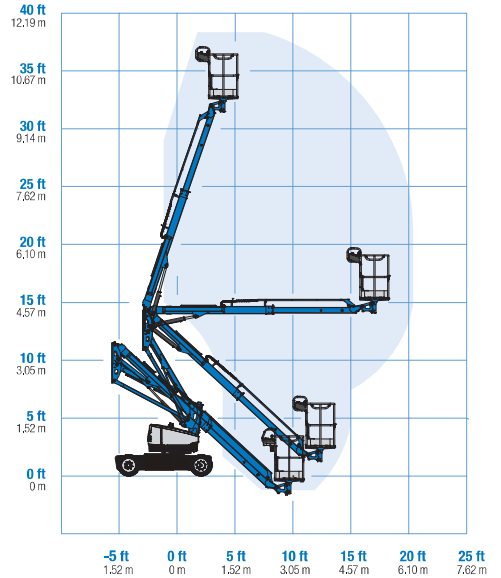

* The metric equivalent of working height adds 2 m to platform height. U.S. adds 6 ft to platform height.
 ** In lift mode (platform raised), the machine is designed to operate on firm, level surfaces only.
 *** Gradeability applies to driving on slopes. See operator's manual for details regarding slope ratings.
 **** Weight will vary depending on options and/or country standards.

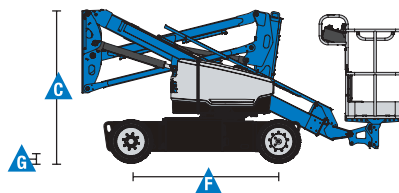
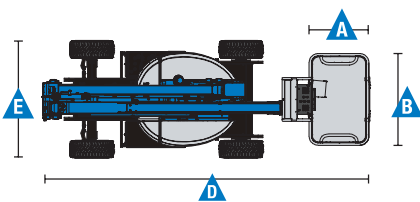

Features

Standard Features

Measurements

- 12 m (38 ft 10 in) working height
- 5.57 m (18 ft 3 in) horizontal reach
- 4.28 m (14 ft 1 in) up and over clearance
- Up to 200 kg (440 lbs) lift capacity

Productivity

- 1.50 m (4 ft 11 in) width
- 1.90 m (6 ft 3 in) inside turning radius
- Self-levelling platform
- Proportional joystick controls
- Thumb rocker steer
- Drive enable
- AC power cord to platform
- Horn
- Hour meter
- Tilt alarm
- Descent & travel alarms
- Flashing beacon
- 400° non-continuous turntable rotation
- Variable speed high efficiency hydraulic power unit
- AC electric drive system
- Traction control
- On board easy to understand diagnostics
- Certified load sensor

Power

- 48 V DC deep cycle battery pack
- 24 V DC auxiliary power
- Universal 30A battery smart charger
- Battery charge indicator
- Low battery voltage interrupt

Drive

- 2 x 4 Electric AC

Tyres

- Solid rubber non-marking
- Multi-surface tyres

Options & Accessories

Productivity

- Air line to platform
- 240 V power to platform
- Work light package
- Lockable platform control box cover



Genie – Toll free number 1800 788 633

Brisbane

HEAD OFFICE
33 Kimberley Street
Darra QLD 4076

Sydney

74 Glendenning Road
Glendenning NSW 2761

Melbourne

374 Hammond Road
Dandenong VIC 3175

Adelaide

16-18 Nixon Road
Wingfield SA 5013

Perth

126 Sheffield Road
Welshpool WA 6106

Darwin

33 McCourt Road
Yarrowonga NT 0830

Genie USA

18340 NE 76th Street
P.O. Box 97030
Redmond, Washington
98073-9730

Distributed By:

Effective Date: December, 2015. Product specifications and prices are subject to change without notice or obligation. The photographs and/or drawings in this document are for illustrative purposes only. Refer to the appropriate Operator's Manual for instructions on the proper use of this equipment. Failure to follow the appropriate Operator's Manual when using our equipment or to otherwise act irresponsibly may result in serious injury or death. The only warranty applicable to our equipment is the standard written warranty applicable to the particular product and sale and we make no other warranty, express or implied. Products and services listed may be trademarks, service marks or trade names of Terex Corporation and/or their subsidiaries in the USA and many other countries. Genie is a registered trademark of Terex South Dakota, Inc. © 2015 Terex Corporation.